

---

## A CAN System Using Multiple MCP25050 I/O Expanders

---

*Author: Diversified Engineering Inc.  
Microchip Technology Inc.*

### INTRODUCTION

The MCP25050 I/O Expander is an effective device used in a Controller Area Network (CAN), which operates without the use of a microcontroller. It supports CAN V2.0B with bit rates up to 1 Mb/s. Since the I/O Expander is a stand-alone device, it can be configured to user defaults using a software template. These defaults are stored in non-volatile EPROM. A network protocol must be chosen that supports a Master Node. The Master Node is required for peer-to-peer communications between I/O Expander Nodes and, therefore, handles communication to and from all I/O Expander Nodes. For this design, we have chosen the CAN-NET protocol, which provides a generic framework for communication that natively supports I/O Expander Nodes. The CAN-NET framework allows users to develop a proprietary protocol for use by their own products.

This application note describes a control system for a scissor-lift, which is essentially a mobile work platform enabling the user to reach relatively high places. The concept behind this vehicle is to have versatile maneuverability along with the ability to control the height. All of the operations and movements for the scissor-lift uses one Master Node and three I/O Expander Nodes. The nodes are distributed throughout the vehicle and are connected together utilizing the 2-wire CAN interface. The master Node consists of a PIC16F874 working with an MCP2510 CAN controller.

With the substantial I/O capability of the expanders, all of the scissor-lift control signals are able to seamlessly communicate with each other. The MCP25050 has many peripherals, such as digital I/O, four 10-bit A/D channels and two PWM outputs with up to 10-bits of resolution. Utilizing the I/O Expanders reduces the size of each node, along with having the ability to control a large system with a few wires, rather than using complex wiring harnesses.

### SYSTEM OVERVIEW

The basic block diagram is shown in Figure 1. All of the actuators in the system, including the traction motors, are hydraulically-based. A single DC motor drives a hydraulic pump and electro-hydraulic valves route the fluid to the appropriate actuator. The operator has complete control of the system from an operator panel located on the work platform. A single axis joystick controls forward and reverse motion, while left and right steering is activated by a thumb-controlled rocker switch on the top of the joystick. Raising and lowering of the platform is accomplished with UP and DOWN push buttons. A battery indicator and horn button are also located on the panel.

# AN816

FIGURE 1: BASIC BLOCK DIAGRAM

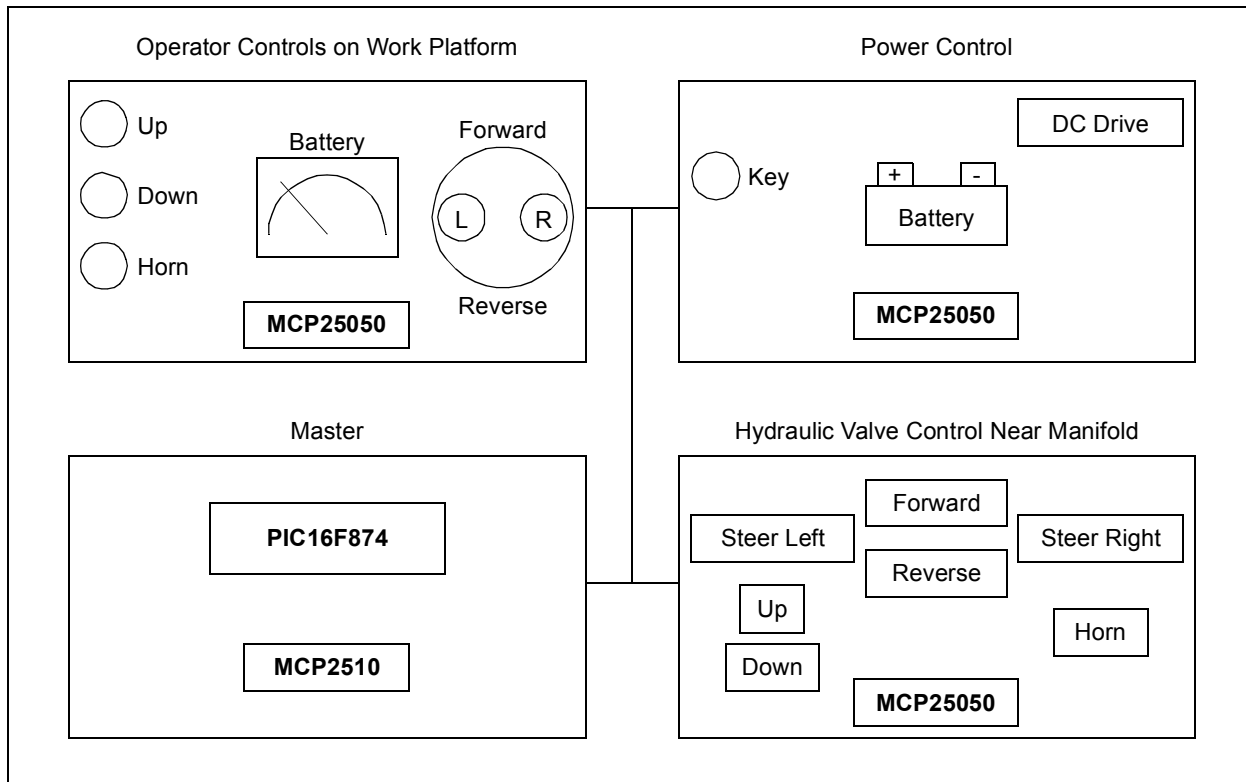

The system uses CAN to bring all of the controls together utilizing the CAN bus, shown in Figure 2. The CAN bus replaces large wiring harnesses and the controls are combined into a node. Each node handles the inputs and outputs along with transmitting and receiving information utilizing the bus. The bus consists of four wires: two power wires and two CAN wires. The master controller supplies the main power and the nodes accept this power from the bus. Each node is regulated at 5V.

**FIGURE 2: SYSTEM DIAGRAM**

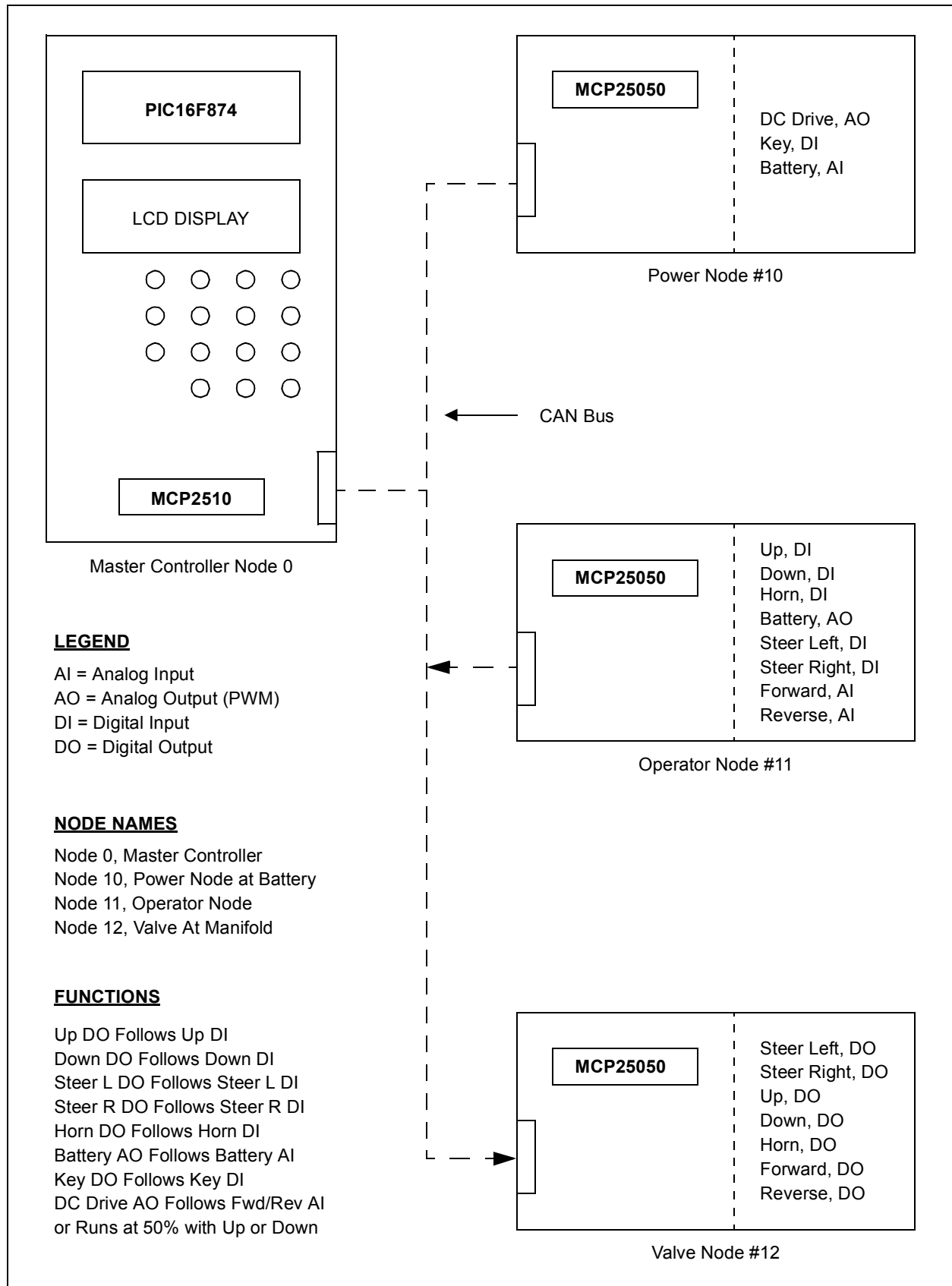

## POWER NODE

The operation of the Power Node is shown in Table 1. The battery input is reduced from 12V and applied to one of the analog inputs on the MCP25050. The DC Drive is controlled by one of the PWM outputs of the MCP25050. The output signal is a PWM signal, which is a filtered DC voltage and adjusts the speed input of the DC Drive. The forward and reverse movement of the joystick determines the duty cycle while the lift is moving. When one of the up or down buttons are depressed, the duty cycle will operate at 50%. A key-switch in the base unit is connected to a digital input on the MCP25050 CAN I/O Expander.

**TABLE 1: OPERATION OF THE POWER NODE**

Operation	Type	Direction	Pin Description
Battery	Analog	Input	AN0
Key	Digital	Input	GP1
DC Drive	PWM	Output	PWM1

## OPERATOR NODE

The operation of the Operator Control Node is shown in Table 2. The Operator Control Node controls all operations of the system from the work platform. The up and down momentary buttons are digital inputs that control their corresponding hydraulic valves and operate the DC Drive at 50% speed. The joystick has a thumb-operated momentary rocker switch for left and right steering. Forward and reverse motion of the lift is controlled by two potentiometers in the joystick, which are connected to two of the analog inputs on the MCP25050. These operations also control their corresponding hydraulic valves. The horn is a momentary button connected to a digital input and controls the horn relay. The battery voltage is displayed on an analog panel meter that is driven from one of the PWM outputs on the MCP25050 CAN I/O Expander.

**TABLE 2: OPERATION OF THE OPERATOR CONTROL NODE**

Operation	Type	Direction	Pin Description
Forward	Analog	Input	AN0
Reverse	Analog	Input	AN1
Battery	PWM	Output	PWM1
Horn	Digital	Input	GP3
Steer Left	Digital	Input	GP4
Steer Right	Digital	Input	GP5
Up	Digital	Input	GP6
Down	Digital	Input	GP7

## VALVE NODE

The operation of the Valve Control Node is shown in Table 3. The Valve Control Node controls the hydraulic valves located at the manifold. All signals come from digital outputs on the MCP25050 CAN I/O Expander.

**TABLE 3: OPERATION OF THE VALVE CONTROL NODE**

Operation	Type	Direction	Pin Description
Up	Digital	Output	GP0
Down	Digital	Output	GP1
Horn	Digital	Output	GP2
Steer Left	Digital	Output	GP3
Steer Right	Digital	Output	GP4
Forward	Digital	Output	GP5
Reverse	Digital	Output	GP6

## HARDWARE OVERVIEW

This reference design was implemented using CAN-NET development boards from Diversified Engineering Inc. The CAN-NET Education board was used for the Master Control Node and the CAN-NET I/O Expander Node was used for all satellite nodes. The CAN-NET I/O Expander Node is a versatile development platform for the MCP25050. Any combination of inputs and outputs can be realized by selecting the proper connections on the I/O header. Schematics for these boards are included in Appendix A.

The CAN data rate selected for this system is 125 kbps.

## CAN-NET GENERAL PURPOSE PROTOCOL

### General Structure

This application note uses a flexible, general-purpose protocol structure that is designed to provide a basic framework for development of specialized proprietary protocols. The goal is simplicity rather than sophistication. We first present the general structure and then customize it to the reference design problem.

The general structure of the 29-bit Extended Message Identifier is divided into two types of messages: Broadcast and Directed. Broadcast messages have no specific destination. Directed messages are sent with one or more specific destinations. Most of the fields of the message identifier are the same for both message types.

The general structure is designed for systems with a maximum of 128 nodes, with each node having a unique address. This restriction can be made flexible by rearranging the number of bits allocated to each field or by adjusting the meaning of the Source and Dest/Subclass fields.

**FIGURE 3: I/O PROTOCOL**

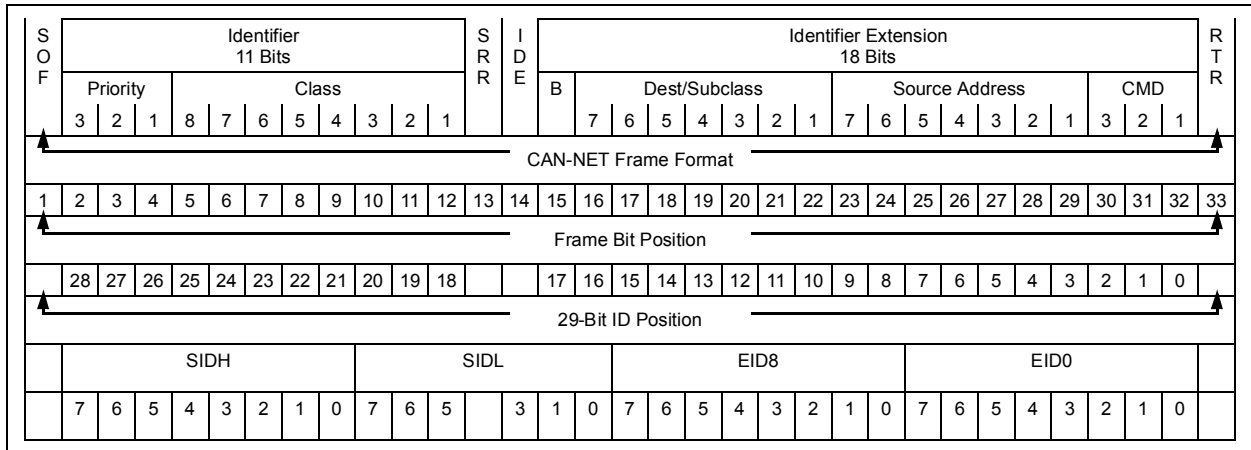

The message identifier is structured into six fields, as shown in the following table. These fields are mapped onto the 29-Bit message ID in the Microchip parts

through the use of four one-byte registers. This mapping is common for the MCP2510 parts and the I/O Expander parts.

**TABLE 4: MESSAGE IDENTIFIERS**

Field Name	# of Bits	Description
Priority	3	Priority: a 0 has priority over a 1.
Class	8	Type of information.
Broadcast	1	0=Directed, 1=Broadcast.
Destination/Subclass	7	Destination or Class dependent modifier.
Source Address	7	Source address
CMD	3	Reserved for hardware restrictions of node

**Priority** - The Priority bits are the upper three bits in the identifier and are used to resolve priority conflicts if two nodes want to transmit at the same time. A '0' has priority over a '1'.

**Class** - The Class categorizes the type of information carried by the message. Eight bits support 256 classes, or types, of information. As will be discussed further, Broadcast type messages have a Subclass field that further expands the number of categories supported.

**Broadcast** - The Broadcast bit is a flag that identifies the message as a Directed message (0) or as a Broadcast message (1).

**Dest/Subclass** - The Dest/Subclass field is a seven-bit field. Its definition depends on the preceding Broadcast flag.

If the message is a Directed message, then this is a Destination field and contains the address of the node or nodes to which the message is directed. A maximum of 128 node addresses is allowed.

If the message is a Broadcast message, then this is a Subclass field that further categorizes the Class of information carried by the message. The meaning of the Subclass field depends on the specific Class.

**Source** - The Source field identifies the node that produced the message. A maximum of 128 node addresses are allowed.

**CMD** - This three-bit field is set aside as an additional extension to the Class field to further identify the contents of the message. It is suggested that it be used to distinguish between multiple message types contained within the same node. This is how the I/O Expander devices use it and it is the only part of the message ID that is hardware determined (in the case of I/O Expander devices) and not adjustable by the user.

# AN816

## CAN-NET PROTOCOL IMPLEMENTATION FOR REFERENCE DESIGN

### Class Definition

The CAN communication for the reference design consists only of messages being exchanged between the Controller Board and I/O Expander nodes (i.e., I/O Expanders cannot generate messages that can be decoded by other I/O Expanders).

**TABLE 5: CLASS DEFINITIONS**

Class	Description
1	CAN I/O Expander data packet containing GPIO digital inputs and A/D values
2	CAN I/O Expander PWM output values
3	CAN I/O Expander Digital outputs
4	All other CAN I/O Expander messages (ignored by Master Controller)

All of the classes have associated data that is formatted in a specific manner that is fixed for an I/O Expander. Detailed information is available in the MCP2502X/5X CAN/I/O Expander (DS21664) Data Sheet.

### Class 1

These messages are generated by the I/O Expander for consumption by the Controller board.

The associated data is an eight-byte data group that contains all the measured data values measured by the MCP25050:

Number of Bits	Bit Name
8 bits	IOINTFL
8 bits	GPIO
4 bytes	AN0H
4 bytes	AN1H
2 bytes	AN10L
4 bytes	AN2H
4 bytes	AN3H
2 bytes	AN23L

- The eight bits of IOINTFL indicate which inputs have changed since the last message.
- The eight bits of GPIO give the state of each of the inputs.
- The four bytes, AN0H, AN1H, AN2H, AN3H, give the upper eight bits of the 10-bit A/D measurement from each activated A/D input.
- The two bytes, AN10L and AN32L, give the lower two bits of the 10-bit A/D measurement from each activated A/D input. The bits are left-justified in the four nibbles that make up the two bytes as follows:
  - AN10L = (AN1:1,AN1:0,0,0 AN0:1,AN0:0,0,0)
  - AN32L = (AN3:1, AN3:0,0,0, AN2:1,AN2:0,0,0)

### Class 2 and 3

These messages are generated by the Controller board for use by the MCP25050 devices.

The data group used by these classes is the "Write Register" command of the MCP25050 devices, which allows the writing of a data value directly into a register of the MCP2505X. In Class 2, the PWM registers are addressed and, in Class 3, the GPLAT register sets the digital output levels.

### Node Addresses

Each node in the system is assigned a unique node address for use in the Source and Dest/Subclass fields.

**TABLE 6: NODE ADDRESSES**

Address	Node
0	Master Controller Node
10	Power Node
11	Operator Control Node
12	Valve Control Node

**TABLE 7: MASTER CONTROLLER  
NODE**

Address '0'	Direction	
	Send	Receive
Priority	0	0
Class	2 or 3	1
Broadcast	No	Yes
Dest/Subclass	10, 11, 12	0
Source	0	10, 11, 12
CMD	0	0

**TABLE 8: POWER NODE**

Address '10'	Direction	
	Send	Receive
Priority	0	0
Class	1, 4	2, 3
Broadcast	Yes	No
Dest/Subclass	0	10
Source	10	0
CMD	0	0

**TABLE 9: OPERATOR CONTROL NODE**

Address '11'	Direction	
	Send	Receive
Priority	0	0
Class	1,4	2,3
Broadcast	Yes	No
Dest/Subclass	0	11
Source	11	0
CMD	0	0

**TABLE 10: VALVE CONTROL NODE**

Address '12'	Direction	
	Send	Receive
Priority	0	0
Class	1, 4	2, 3
Broadcast	Yes	No
Dest/Subclass	0	12
Source	12	0
CMD	0	0

## SOFTWARE OVERVIEW

Configuring the MCP25050 devices consists of providing arguments to a set of macros that generate a data table for MASM. In this sense, I/O Expander devices are configured rather than programmed.

The Controller board is programmed in the normal fashion, but the specific details of the programming are not particularly important for the reference design since the primary purpose of the Controller board is to receive messages from the I/O Expanders and repackage the data to be sent to the other I/O Expanders.

## I/O EXPANDER CONFIGURATION

For I/O Expander configurations that are static (i.e., the configuration is not changed dynamically over the network) the important configuration parameters fall into two categories: network related items and I/O functions.

Choosing network values other than the message ID's consist primarily in calculating the networking parameters determined by clock frequency and other physical characteristics of the network. The message ID's for transmitting and receiving messages are determined by the network protocol selected. For the reference design, the message ID selection is described in detail above.

The MCP25050 can be configured to perform up to eight I/O functions. There are eight digital inputs, seven digital outputs, four 10-bit A/D channels and two PWM outputs with up to 10-bits of resolution. Available with

each of the I/O types are associated support functions, such as message transmission triggered by a change in input. Scheduled message transmission can be used in addition to on-change messaging to insure the network is routinely informed of the current state of the inputs, even if none of them have changed. A combination of scheduled and on-change messages is often the best solution to routine updates with rapid response to change.

The data selections for this application note are in the following files:

**TABLE 11: DATA SELECTIONS**

File	Description
OPERNODE.ASM	Operator Board
MAINNODE.ASM	Main Board
VALVNODE.ASM	Hydraulic Valve Board

## CONTROLLER BOARD SOFTWARE

The Controller board software is written to operate on the Diversified Engineering CAN-NET Education Board. The code for the CAN-NET board is written in the PIC® instruction set to be assembled using Microchip's MPLAB® environment. There is significant use of macros to make the code more readable and less error prone. In addition to the macros defined at the top of the individual files, a large number of macros can be found in the MACROS16.INC file. If you come across an unfamiliar instruction when reading the code, it probably is a macro. Macros are in MACROS16.INC and used extensively in writing code for PICmicro® microcontrollers and have increased readability and greatly reduce programming errors.

To simplify the source code, the code that handles the LCD display and keypad input was removed. What remains is the initialization code that sets up the ports and initializes the MCP2510 CAN controller, in addition to a main loop that checks for CAN messages from the I/O Expander nodes and sends messages to the nodes.

The technique used by the program is to maintain a local set of variables that fully represent the state of the system. The variables are updated by messages received from the I/O Expander nodes, with the new values being sent to the appropriate I/O Expanders.

# AN816

Nine digital flags that contain the current state of the associated buttons or outputs represent the binary values.

**TABLE 12: DIGITAL FLAGS**

tbFlgUp	Up
tbFlgDown	Down
tbFlgHorn	Horn
tbFlgLeft	Left
tbFlgRight	Right
tbFlgForward	Forward
tbFlgReverse	Reverse
tbFlgBattery	Battery LED
tbFlgKeyLED	Key LED
tbFlgKey	Key

The four analog variables are represented by four 1-byte quantities.

**TABLE 13: ANALOG VARIABLES**

bBatteryLevel	Battery level 0 -> 255
bDCDrive	DC Drive control level: 0 -> 255
bForward	Joy stick level: 0 -> 255
bReverse	Joy stick level: 0 -> 255

Each time a message is received from a MCP25050, the received data is used to update the local binary and analog variables that maintain the state of the system. If a binary or analog value is received that should be sent to another of the I/O Expanders in the system, a flag is set indicating that a message should be sent to that I/O Expander.

Each time around the main loop, incoming messages are parsed and messages are generated for the I/O Expanders.

The only calculations done by the controller board software are for the operation of the DC drive motor. The two analog values from the forward and reverse joystick inputs on the Operator Control Board are converted to a single PWM for the DC Drive and binary forward or reverse valve positions. A dead band is imposed so that the exact center of the joystick need not be known. Other than these calculations, the input data is sent back out to the appropriate node.

The controller software is contained in the files:

**TABLE 14: CONTROLLER SOFTWARE**

File	Description
MCP2510.inc	Definitions and macros for 2510 support
Macros16.inc	Support macros
MainExp.asm	Main program
RefCode.asm	Code specific to the Reference Design
Ref.asm	I/O Expander Reference Design
Canlib.asm	2510 support functions
Lcd4bit.asm	LCD Handler
OperExp.asm	Operator Control Board
ValveExp.asm	Valve Control Board

## CONCLUSION

The MCP25050 CAN I/O Expanders are an excellent and effective solution for new or existing systems. The advantage of the MCP25050 CAN I/O Expander is that an extra controller is not needed per node in order to utilize the CAN engine. Another advantage is that several I/O Expanders can work from the same CAN bus, rather than using large and complicated wiring harnesses. This design demonstrates a useful way to integrate the I/O Expanders in a system using different types of inputs and outputs, while also providing a stepping stone to quickly start similar projects. From this example, several functions can be implemented simply by using the basic techniques from this design.

## CONTACTING DIVERSIFIED ENGINEERING

Additional information and CAN-related products may be obtained from Diversified Engineering by calling:

(203) 799-7875

or by visiting their web site:

[www.DiversifiedEngineering.net](http://www.DiversifiedEngineering.net)

## SOURCE CODE

Because of its overall size and the number of files needed for the controller software, a complete source file is not provided. A single WinZip archive file containing the complete source code may be downloaded from the Microchip corporate Web site at

[www.microchip.com](http://www.microchip.com).



## APPENDIX A: CAN-NET BOARD SCHEMATICS

### FIGURE A-1: MAIN CAN-NET BOARD SCHEMATIC

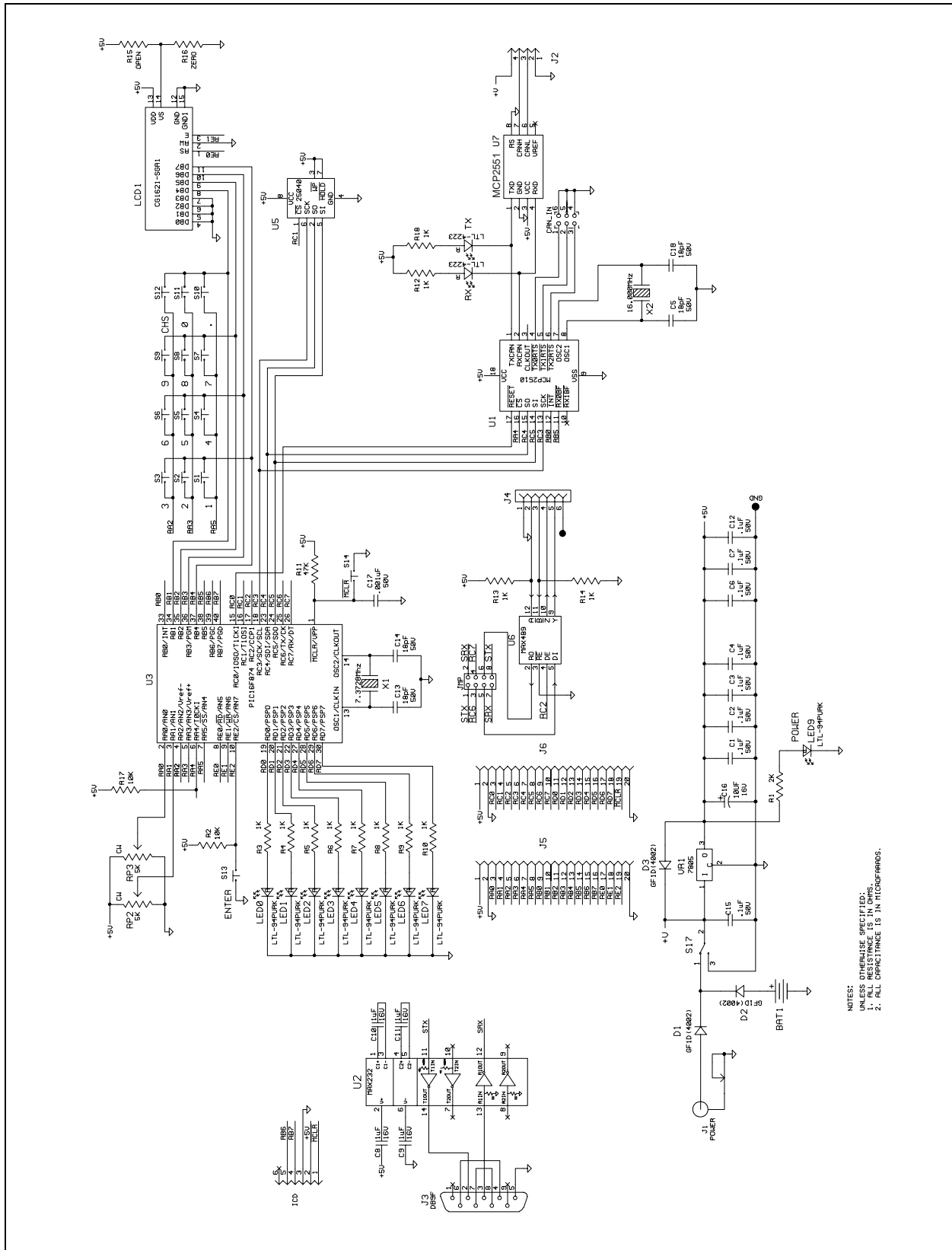

# AN816

FIGURE A-2: CAN I/O EXPANDER SCHEMATIC (1 OF 2)

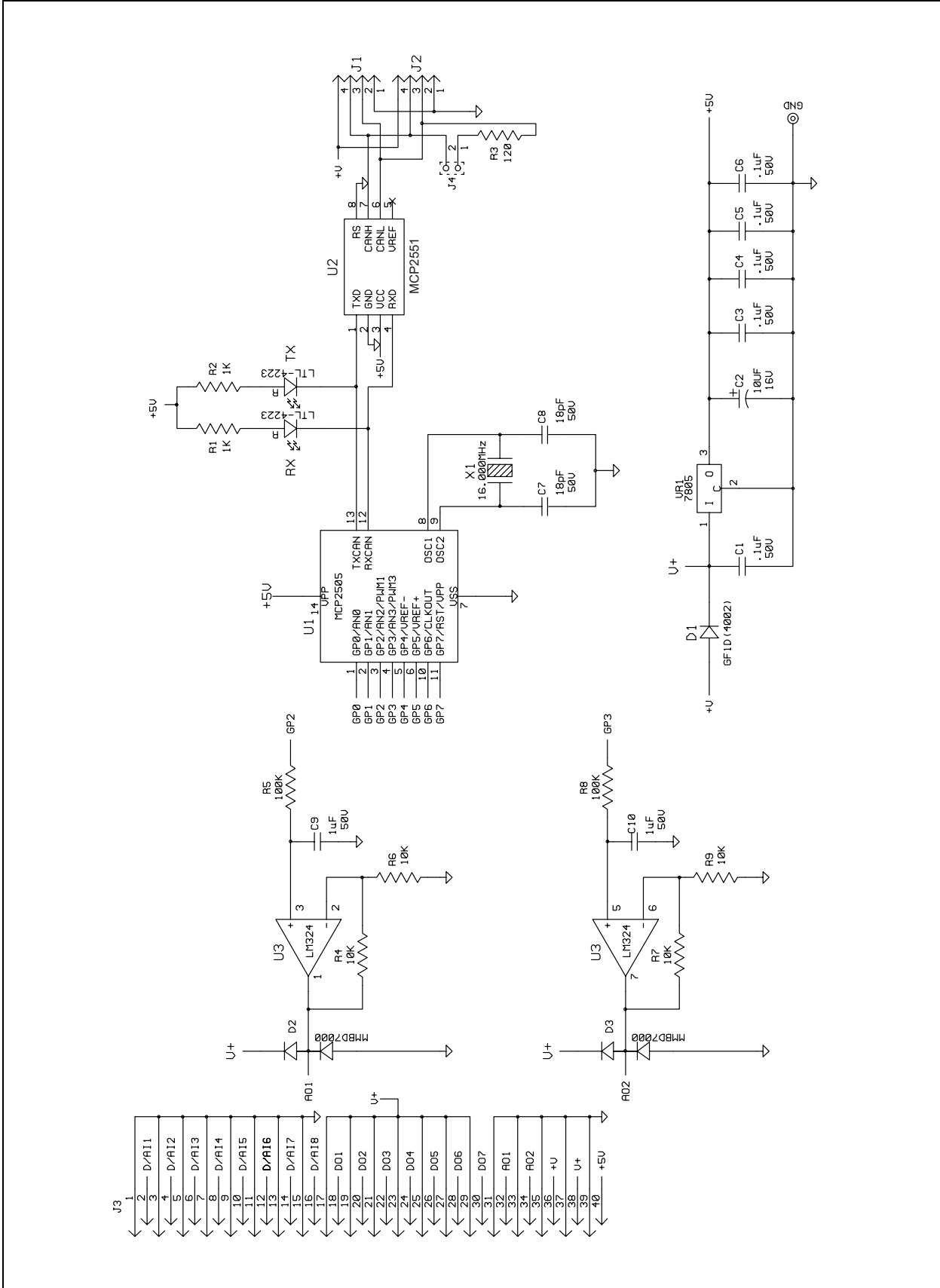

**FIGURE A-3: CAN I/O EXPANDER SCHEMATIC (2 OF 2)**

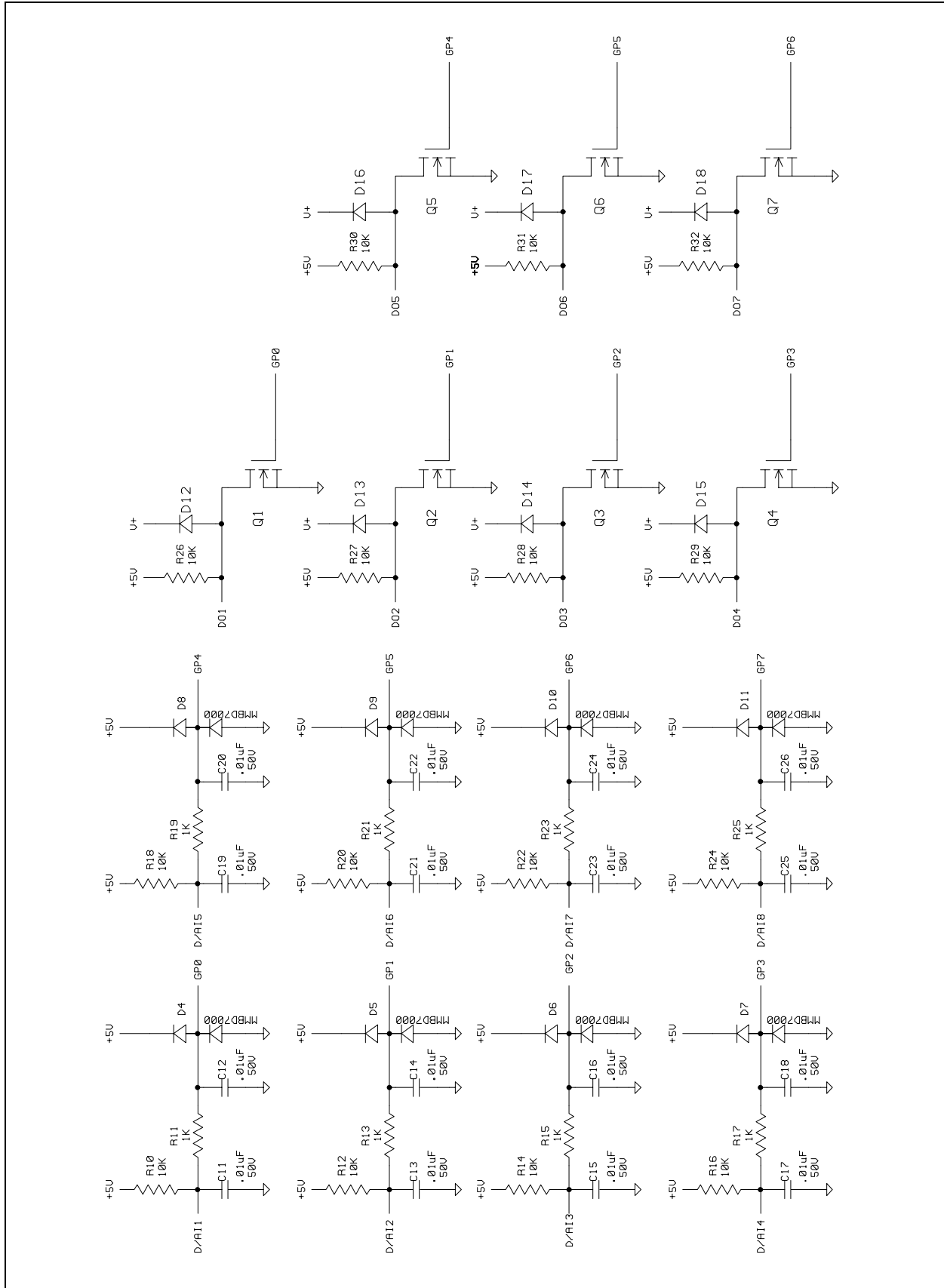

# AN816

---

NOTES:

---

Information contained in this publication regarding device applications and the like is intended through suggestion only and may be superseded by updates. It is your responsibility to ensure that your application meets with your specifications. No representation or warranty is given and no liability is assumed by Microchip Technology Incorporated with respect to the accuracy or use of such information, or infringement of patents or other intellectual property rights arising from such use or otherwise. Use of Microchip's products as critical components in life support systems is not authorized except with express written approval by Microchip. No licenses are conveyed, implicitly or otherwise, under any intellectual property rights.

#### Trademarks

The Microchip name and logo, the Microchip logo, KEELOQ, MPLAB, PIC, PICmicro, PICSTART and PRO MATE are registered trademarks of Microchip Technology Incorporated in the U.S.A. and other countries.

FilterLab, microID, MXDEV, MXLAB, PICMASTER, SEEVAL and The Embedded Control Solutions Company are registered trademarks of Microchip Technology Incorporated in the U.S.A.

dsPIC, dsPICDEM.net, ECONOMONITOR, FanSense, FlexROM, fuzzyLAB, In-Circuit Serial Programming, ICSP, ICEPIC, microPort, Migratable Memory, MPASM, MPLIB, MPLINK, MPSIM, PICC, PICDEM, PICDEM.net, rPIC, Select Mode and Total Endurance are trademarks of Microchip Technology Incorporated in the U.S.A. and other countries.

Serialized Quick Turn Programming (SQTP) is a service mark of Microchip Technology Incorporated in the U.S.A.

All other trademarks mentioned herein are property of their respective companies.

© 2002, Microchip Technology Incorporated, Printed in the U.S.A., All Rights Reserved.

 Printed on recycled paper.

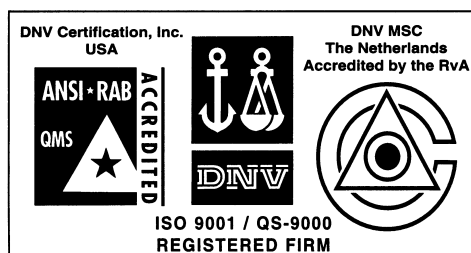

*Microchip received QS-9000 quality system certification for its worldwide headquarters, design and wafer fabrication facilities in Chandler and Tempe, Arizona in July 1999 and Mountain View, California in March 2002. The Company's quality system processes and procedures are QS-9000 compliant for its PICmicro® 8-bit MCUs, KEELOQ® code hopping devices, Serial EEPROMs, microperipherals, non-volatile memory and analog products. In addition, Microchip's quality system for the design and manufacture of development systems is ISO 9001 certified.*



# MICROCHIP

## WORLDWIDE SALES AND SERVICE

### AMERICAS

#### Corporate Office

2355 West Chandler Blvd.  
Chandler, AZ 85224-6199  
Tel: 480-792-7200 Fax: 480-792-7277  
Technical Support: 480-792-7627  
Web Address: <http://www.microchip.com>

#### Rocky Mountain

2355 West Chandler Blvd.  
Chandler, AZ 85224-6199  
Tel: 480-792-7966 Fax: 480-792-4338

#### Atlanta

500 Sugar Mill Road, Suite 200B  
Atlanta, GA 30350  
Tel: 770-640-0034 Fax: 770-640-0307

#### Boston

2 Lan Drive, Suite 120  
Westford, MA 01886  
Tel: 978-692-3848 Fax: 978-692-3821

#### Chicago

333 Pierce Road, Suite 180  
Itasca, IL 60143  
Tel: 630-285-0071 Fax: 630-285-0075

#### Dallas

4570 Westgrove Drive, Suite 160  
Addison, TX 75001  
Tel: 972-818-7423 Fax: 972-818-2924

#### Detroit

Tri-Atria Office Building  
32255 Northwestern Highway, Suite 190  
Farmington Hills, MI 48334  
Tel: 248-538-2250 Fax: 248-538-2260

#### Kokomo

2767 S. Albright Road  
Kokomo, Indiana 46902  
Tel: 765-864-8360 Fax: 765-864-8387

#### Los Angeles

18201 Von Karman, Suite 1090  
Irvine, CA 92612  
Tel: 949-263-1888 Fax: 949-263-1338

#### San Jose

Microchip Technology Inc.  
2107 North First Street, Suite 590  
San Jose, CA 95131  
Tel: 408-436-7950 Fax: 408-436-7955

#### Toronto

6285 Northam Drive, Suite 108  
Mississauga, Ontario L4V 1X5, Canada  
Tel: 905-673-0699 Fax: 905-673-6509

### ASIA/PACIFIC

#### Australia

Microchip Technology Australia Pty Ltd  
Suite 22, 41 Rawson Street  
Epping 2121, NSW  
Australia  
Tel: 61-2-9868-6733 Fax: 61-2-9868-6755

#### China - Beijing

Microchip Technology Consulting (Shanghai)  
Co., Ltd., Beijing Liaison Office  
Unit 915  
Bei Hai Wan Tai Bldg.  
No. 6 Chaoyangmen Beidajie  
Beijing, 100027, No. China  
Tel: 86-10-85282100 Fax: 86-10-85282104

#### China - Chengdu

Microchip Technology Consulting (Shanghai)  
Co., Ltd., Chengdu Liaison Office  
Rm. 2401, 24th Floor,  
Ming Xing Financial Tower  
No. 88 TIDU Street  
Chengdu 610016, China  
Tel: 86-28-86766200 Fax: 86-28-86766599

#### China - Fuzhou

Microchip Technology Consulting (Shanghai)  
Co., Ltd., Fuzhou Liaison Office  
Unit 28F, World Trade Plaza  
No. 71 Wusi Road  
Fuzhou 350001, China  
Tel: 86-591-7503506 Fax: 86-591-7503521

#### China - Shanghai

Microchip Technology Consulting (Shanghai)  
Co., Ltd.  
Room 701, Bldg. B  
Far East International Plaza  
No. 317 Xian Xia Road  
Shanghai, 200051  
Tel: 86-21-6275-5700 Fax: 86-21-6275-5060

#### China - Shenzhen

Microchip Technology Consulting (Shanghai)  
Co., Ltd., Shenzhen Liaison Office  
Rm. 1315, 13/F, Shenzhen Kerry Centre,  
Renminnan Lu  
Shenzhen 518001, China  
Tel: 86-755-82350361 Fax: 86-755-82366086

#### China - Hong Kong SAR

Microchip Technology Hongkong Ltd.  
Unit 901-6, Tower 2, Metroplaza  
223 Hing Fong Road  
Kwai Fong, N.T., Hong Kong  
Tel: 852-2401-1200 Fax: 852-2401-3431

#### India

Microchip Technology Inc.  
India Liaison Office  
Divyasree Chambers  
1 Floor, Wing A (A3/A4)  
No. 11, O'Shaughnessy Road  
Bangalore, 560 025, India  
Tel: 91-80-2290061 Fax: 91-80-2290062

### Japan

Microchip Technology Japan K.K.  
Benex S-1 6F  
3-18-20, Shinyokohama  
Kohoku-Ku, Yokohama-shi  
Kanagawa, 222-0033, Japan  
Tel: 81-45-471-6166 Fax: 81-45-471-6122

### Korea

Microchip Technology Korea  
168-1, Youngbo Bldg. 3 Floor  
Samsung-Dong, Kangnam-Ku  
Seoul, Korea 135-882  
Tel: 82-2-554-7200 Fax: 82-2-558-5934

### Singapore

Microchip Technology Singapore Pte Ltd.  
200 Middle Road  
#07-02 Prime Centre  
Singapore, 188980  
Tel: 65-6334-8870 Fax: 65-6334-8850

### Taiwan

Microchip Technology (Barbados) Inc.,  
Taiwan Branch  
11F-3, No. 207  
Tung Hua North Road  
Taipei, 105, Taiwan  
Tel: 886-2-2717-7175 Fax: 886-2-2545-0139

### EUROPE

#### Austria

Microchip Technology Austria GmbH  
Durisolstrasse 2  
A-4600 Wels  
Austria  
Tel: 43-7242-2244-399  
Fax: 43-7242-2244-393

#### Denmark

Microchip Technology Nordic ApS  
Regus Business Centre  
Lautrup høj 1-3  
Ballerup DK-2750 Denmark  
Tel: 45 4420 9895 Fax: 45 4420 9910

#### France

Microchip Technology SARL  
Parc d'Activite du Moulin de Massy  
43 Rue du Saule Trapu  
Batiment A - 1er Etage  
91300 Massy, France  
Tel: 33-1-69-53-63-20 Fax: 33-1-69-30-90-79

#### Germany

Microchip Technology GmbH  
Steinheilstrasse 10  
D-85737 Ismaning, Germany  
Tel: 49-89-627-144 0 Fax: 49-89-627-144-44

#### Italy

Microchip Technology SRL  
Centro Direzionale Colleoni  
Palazzo Taurus 1 V. Le Colleoni 1  
20041 Agrate Brianza  
Milan, Italy  
Tel: 39-039-65791-1 Fax: 39-039-6899883

#### United Kingdom

Microchip Ltd.  
505 Eskdale Road  
Wokingham  
Berkshire, England RG41 5TU  
Tel: 44 118 921 5869 Fax: 44-118 921-5820

10/18/02